

STX 2100 SERIES DIFFERENTIAL PRESSURE



- $\pm 0.1\%$ accuracy
- Ranges from 3.75mbar to 20 bar
- 16:1 rangeability
- Line Pressure up to 140 bar
- 2-wire 4-20mA with HART® protocol
- Robust and Modular Design
- Local zero and span adjustment

Smart/HART® Differential Pressure Transmitter

The STX 2100 Series Differential Pressure Transmitter complements the STX 2000 Series, providing a complete family of Smart gauge, absolute and differential units. Featuring a unique floating sensor design and state-of-the-art electronics incorporating the HART® protocol, the STX 2100 Series provides enhanced performance and digital two-way communication.

At the heart of the instrument is a micro-capacitance silicon sensing element which floats remotely from the isolation diaphragms. Silicon has excellent mechanical properties, being perfectly free from hysteresis, and enables repeatability of better than 0.01% to be achieved. Wide measurement capability results in a standard sensor design covering all pressure ranges, enabling the use of process connections with 54mm centres to DIN 19213 throughout.

The electronics assembly is modular and utilises surface mounted components and ASIC (Application Specific Integrated Circuit) technology to create a neat and compact electronics unit. As the compensation data is stored in an EEPROM within the sensing element, the electronics can easily be replaced in the field without the need to re-characterize the complete assembly. The microprocessor performs selectable damping, high or low failure alarm, linear or square root output function and write protection to inhibit any unauthorised change of instrument configuration. The optional LCD indicator is available configured in a number of display options: 0-100% linear, engineering units or 0-100% square root scale independent of transmitter analogue output.

STANDARD SPECIFICATION

Pressure Measurement Specification

Standard Ranges

The transmitter is available in the following standard (zero based) ranges or calibrated to any acceptable intermediate span specified:-

- 0-3.75mbar to 0-60mbar differential (Static pressure limit: 32 bar)
- 0-20mbar to 0-320mbar differential
- 0-81.25mbar to 0-1.3 bar differential
- 0-312.5mbar to 0-5 bar differential
- 0-1.25 bar to 0-20 bar differential (Static pressure limit: 140 bar)

Range Adjustment

Span setting:-

The transmitter output can be adjusted to give a full 4-20mA output change for any span down to 6.25% of the Upper Range Limit (URL) e.g. a 320mbar device can be adjusted down to a minimum span of 20mbar (16:1 down-ranging). Zero offset:- The zero (4mA) output of the transmitter can be set anywhere within the range -100% to +93.75% of the URL e.g. a 320mbar device can be adjusted to give 4-20mA for -320 to 0mbar. At the minimum span of 20mbar, the same device could also be calibrated to give 4-20mA for 300 to 320mbar.



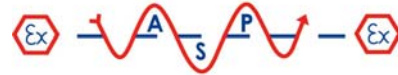

Overpressure: The device can withstand overpressure to the static pressure limit as stated above on either side without damage to the sensor.

Pressure Containment

Application of pressure beyond the static pressure limit and up to 350 bar (150 bar for 60mbar unit) may damage the sensor but process media leakage will not occur.

Process Media

Any liquid, gas or vapour compatible with 316 stainless steel with either viton or PTFE process seals. Metallic wetted parts comply with NACE MR-01-75.

Output Current

4-20mA (2 wire configuration) linear or square root proportional to the calibrated pressure range, with HART® digital signal superimposed.

Performance

Specifications

Accuracy

±0.1% of calibrated span including the combined effects of non-linearity, hysteresis and repeatability for spans between 1:1 and 10:1 URL.

For spans below 10:1

$$\pm \left[0.05 + \left(0.05 \times \frac{0.1 \times \text{URL}}{\text{Span}} \right) \right] \% \text{ of span}$$

Transmitter Supply Voltage

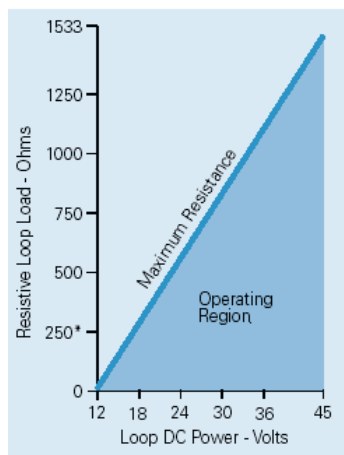

Long Term Stability

At standard reference conditions, the calibration will not change by more than 0.1% URL over 12 months.

Operating Temperature Range

Ambient -40° to +85°C
(-20° to +80°C for LCD indicator)
(-10° to +60°C for fluorinated oil filled transmitters)
Process: -40° to +100°C
(-20° to +80°C for fluorinated oil filled transmitters)
Storage: -40° to +90°C

Temperature Effects

Zero shift: better than ±0.5% URL/55°C
Total shift: better than ±1% URL/55°C

Static Pressure Effect

Zero shift (%URL):-
60mbar range: maximum ±0.4%/32 bar
All other ranges: maximum ±0.2%/100 bar
Note: Correctable by adjusting zero at line pressure
Span shift (% calibrated span):-
60mbar range: maximum ±0.4%/32 bar
All other ranges: maximum - 0.5%/100 bar

Overrange Effect

Zero shift at maximum line pressure (%URL): ±0.4%

Supply Sensitivity

Less than 0.005% of calibrated span per volt.

Mounting Position Effect

Zero shift less than 1.2mbar for a 10° tilt in any plane, correctable by adjusting zero. No effect on span.

*Note:- 250 Ohms minimum loop resistance required for optional HART® communications. (The STX 2100 will function in standard analogue mode with less than 250 Ohms).

Failure Mode Alarm

User selectable upscale or downscale drive or hold output under detected failure conditions.

Turn-on time: 4 seconds.

Damping: Adjustable between 0 and 38.4 seconds.

Hazardous Area Approvals

Approved to International Standards for Intrinsic Safety and Flameproof Certification:-

Intrinsic Safety Certification:-
CE II 1 GDEEx ia IIC T5 (Ta = 40°C)
1180 EEx ia IIC T4 (Ta = 80°C)

Flameproof Certification:-
CE II 2 GD Ex ds IIC T6 (Ta = 65°C)
1180 Ex ds IIC T5 (Ta = 85°C)

Type N Certification:-
CE II 3 GD Ex nL IIC T5 (Ta = 40°C)
1180 Ex nL IIC T4 (Ta = 80°C)

All options are compliant with EMC Directive 89/336/EEC

Physical Specifications

Electrical Connections

The threaded electrical conduit connections can be specified as M20, 1½-14 NPT or PG 13.5 female.

Process Connections

The process connections can be specified as 1¼-18 NPT female or 1½-14 NPT female (via adaptors) on 54mm centres to DIN19213.

Electronics Housing

Low copper aluminium alloy, with epoxy double coating. Environmental Protection: IP67, NEMA 4X.

Bolt and Nut Fastenings

Cr-Mo alloy or optional 304 stainless steel. Note: Static pressure rating is limited to 100 bar with 304 stainless steel bolts.

Fill fluid: Silicone oil or optional fluorinated oil.

Shipping Weight

Standard Transmitter: 3.4kg approx. Add 800gms for LCD indicator, 500gms for mounting bracket.

OPTIONS

Integral digital indicator with 5 digit LCD Mounting bracket for 2" pipe in 304 stainless steel.

ACCESSORIES

HART® communication tools, remote diaphragm seals and manifold valves are also available.



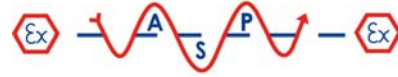

ORDERING INFORMATION

Please state the following:

X 21	Base Model Number		
Code	Diaphragm	Process Flanges	Fill Fluid
00	316L stainless steel	316 stainless steel	Silicone Oil
10	316L stainless steel	316 stainless steel	Fluorinated Oil
	Code Range		
01	0 - 3.75mbar	to 0 - 60mbar	
03	0 - 20mbar	to 0 - 320mbar	
06	0 - 81.25mbar	to 0 - 1.3 bar	
09	0 - 312.5mbar	to 0 - 5 bar	
13	0 - 1.25 bar	to 0 - 20 bar	
	Code	Process Connection	Conduit Entry
	1	1/4 - 18 NPT	M20
	2	1/2 - 14 NPT (via adaptors)	M20
	3	1/4 - 18 NPT	1/2 - 14 NPT
	4	1/2 - 14 NPT (via adaptors)	1/2 - 14 NPT
	5	1/4 - 18 NPT	PG 13.5
	6	1/2 - 14 NPT (via adaptors)	PG 13.5
	Code	Sensor 'O' Ring	
	A	Viton	
	B	PTFE	
	Code	Bolt/Nut Materials	
	1	Cr/Mo alloy	
	2	304 stainless steel	
	Code	Approvals	
	O	Safe Area	
	I	Intrinsically Safe	
	D	Flameproof	
	N	Type N	
	Code	Options	
	O	None	
	L	Digital indicator, 0-100% Linear	
	C	Digital indicator, custom scale	
	S	Digital indicator, 0-100% sq. root scale	
	B	Mounting bracket, 304 stainless steel	

X2100 - 01 - 1 - A - 2 - I - LB Typical Model Number.

Installation

Drawings -
dimensions in mm.

*LCD indicator
option: 98

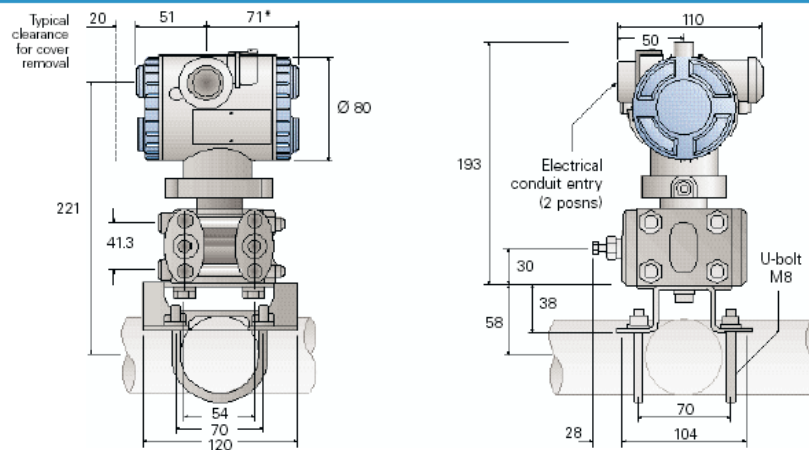

Supplied by:

A.S.P. Electro-Technology Ltd

39 London Road, Hinckley, LE10 1HQ. U.K.
Tel: +44 (0)1455 635796 Fax: +44 (0)1455 251110
Email: sales@asp-electro-tech.com
Web: asp-electro-tech.com



This publication is not intended to form the basis of a contract. All the above specifications, dimensions, weights, tolerances etc are typical and may be varied or changed by the manufacturer without prior notice. A.S.P. Electro-Technology accept no liability for consequence of use.