

A.S.P. Electro-Technology Ltd
INFORMATION SHEET

6 Series EEx de Bulkhead Luminaire 621 range

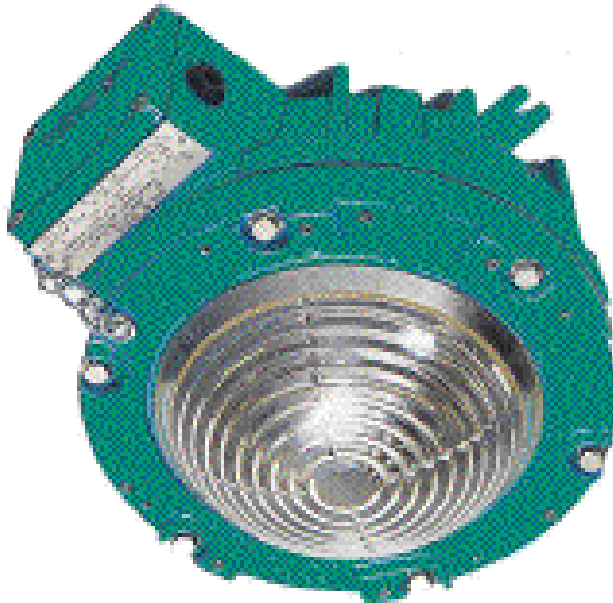

Features

- ✘ Low projection for narrow corridors and low ceiling applications
- ✘ Lightweight, compact construction
- ✘ Simple re-lamping with standard lamps
- ✘ Extensive lamp options

Certification & Approval

| | |
|-------------------------|--|
| Certification Code: | EEx de IIB or IIC T3 to T6 (Dependent upon lamp source-see data) |
| Certification Standard: | BS5501 Parts 1, 5 and 6 (EN50014-018-019) IIB and IIC on options available at standard ambients are all Atex approved. |
| Certificate Number: | SIRA 00 Atex 1047 SIRA Ex 94C 1043 IP 66 to IEC 529 |
| Degree of Protection: | |

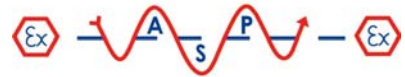

Protective guard • Cast guard available at extra cost.

| | | |
|--------|--------|-------|
| Weight | SON | 13kg |
| | HPMV | 13kg |
| | GLS | 10 kg |
| | 25w SL | 11kg |

How To Order

Product codes are formed as follows:

| Series Ref. | Lamp Size & Type | Voltage | Frequency |
|-------------|------------------|----------|-----------|
| 621 | e.g. 125w HPMV | e.g. 240 | e.g. 50 |

and written: 621 / 125w HPMV / 240 / 50

Special features

specified using the following codes:

| | |
|---------|--------------------------|
| /Pg13.5 | Pg 13.5 cable entries |
| /WG | Wire Guard |
| /HT | High ambient temperature |

These are added to the product codes as required: e.g. 621 / 125w HPMV / 240 / 50 / WG / HT

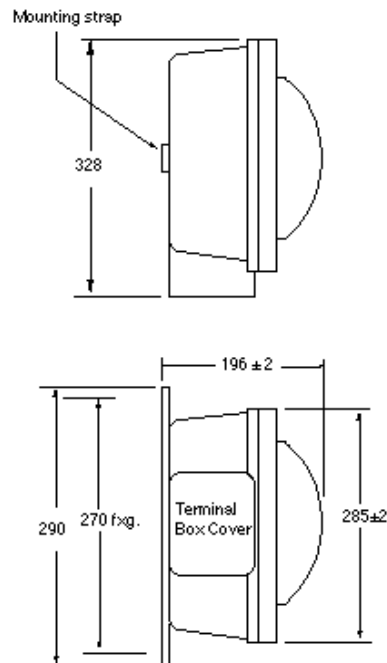

Supplied by:

A.S.P. Electro-Technology Ltd



39 London Road, Hinckley, LE10 1HQ. U.K.
Tel: +44 (0)1455 635796 Fax: +44 (0)1455 251110
Email: sales@asp-electro-tech.com
Web: asp-electro-tech.com

This publication is not intended to form the basis of a contract. All the above specifications, dimensions, weights, tolerances etc are typical and may be varied or changed by the manufacturer without prior notice. A.S.P. Electro-Technology accept no liability for consequence of use.