

XB11 SL STATUS LAMPS - Explosion-proof, Weatherproof & SM87 SL

Introduction

These ranges of versatile status lights have been designed to suit various offshore and onshore applications.

Available as LED, xenon, filament and fluorescent beacons.

The SM87 SL range is manufactured in marine grade alloy and the XB11 SL in corrosion-free GRP to provide a wide range of status lights to suit clients' requirements.

All units can be supplied as 1, 2, 3 or 4 way.



Note: Units shown are for illustration only. Other variations are available.

- Zone 1 and Zone 2 use.
- EExd.
- *ATEX approved, Ex II 2GD.
- *BASEEFA certified.
- *UL listed for USA and Canada
- Class I, Div. 1 & 2, Groups C & D
- Class I, Zone 1, AExd IIB T6.
- *CSA certified.
- *GOST 'R' & 'K' certified.
- IP66 & 67.
- *Certified temperature -55°C to +70°C.
- *LED, xenon, fluorescent, filament.
- Marine grade alloy or GRP.
- Close-coupled and pre-wired to customer's requirements.
- *Model dependant.

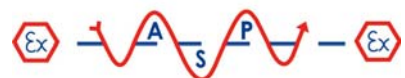

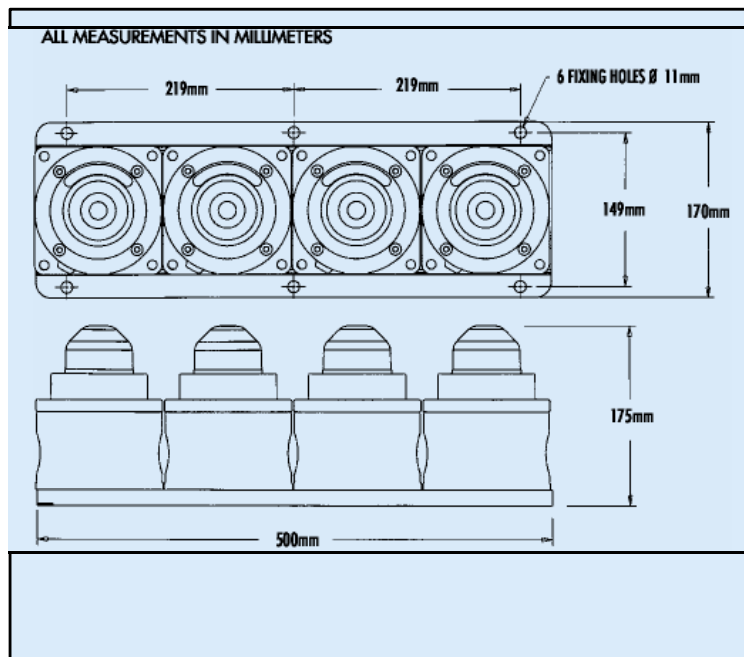
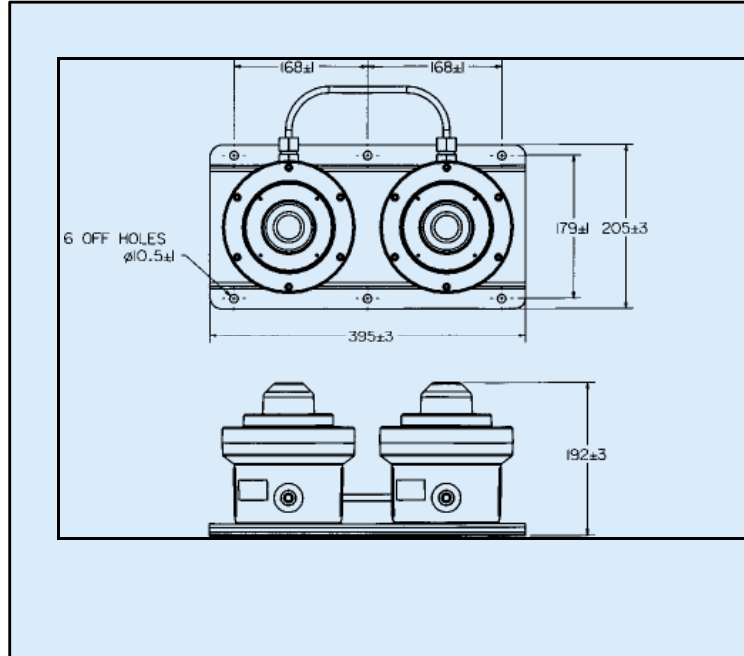
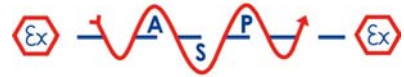



Lamp Types	S M 8 7 S L	X B 1 1 S L
		LED 192 Candela Xenon 6 joules maximum. Fluorescent 10W or 5W. Filament 40W maximum.
Voltage Frequency	50 Hz as standard. 60 Hz available if required.	
Xenon Voltages	24, 48V d.c. 110, 120, 240, 254V a.c. (see SM87 HXB data sheet for further information)	24V d.c., 110V, 240V a.c. (see XB11 data sheet for further details)
Filament Voltages	12, 24, 48V d.c., 110, 220, 240, 254V a.c. (see SM87 LU3 data sheet for further information)	24, 48V d.c., 110, 220, 240, 254V a.c. (see FL11* data sheet for further details)
Fluorescent Voltages	12, 24, 48V, 220, 240, 254V a.c. (see SM87 LU1 data sheet for further information)	24V d.c., 240V a.c. (see FL11* data sheet for further details)
Lamp Colours	Red, Amber, Yellow, Green, Blue or Clear.	
Certification	ATEX Approved: EExd IIC T4 (filament), EExd IIC T6 (Fluorescent & Xenon). Cert. No. Baseefa 03ATEX0222X CENELEC EN50014, EN50018 UL Listed for USA and Canada: Class I, Div 1, Groups C & D, Class I, Zone 1, AExd IIB T6, Listing No. E187894. CSA Certified: Class I, Div 1 & 2, Group D. Cert. No. 96406. GOST 'R' & 'K' Certified: 1 Exd IIC T4.	ATEX Approved: BASEEFA EExd IIB T5/T6. Cert. No. 99 ATEX 2195x CENELEC EN50014 and EN50018. UL Listed for USA and Canada: Class I, Div 2, Groups C & D, Class I, Zones 1 & 2, AExd IIB T5/T6. Listing No. E187894 (XB11 only).
Terminals	2.5mm ² max.	
Wiring	Standard configuration of internal wiring is to common the negative/neutral connections. If individually wired lamps are required, please state requirements.	
Entries	Up to 3 x 20mm or 25mm ISO.	1 x 20mm.
Enclosure	LM 25TF Marine Grade Alloy.	GRP.
Lens	Glass	
Finish	Epoxy paint as standard or to customer's specification.	Natural Black or Epoxy paint to customer's specification.
Ingress Protection	IP66 & 67.	
Ambient Temp.	-25°C to +55°C (LED & Fluorescent). -55°C to +70°C (Xenon & Filament).	-55°C to +70°C.
Gland Type	Exd	

*NOTE: FL11 currently not available UL listed.

Supplied by:

A.S.P. Electro-Technology Ltd
Specialist Suppliers of Hazardous Area Certified
Electrical Products & Instrumentation

39 London Road, Hinckley, LE10 1HQ. U.K.
Tel: +44 (0)1455 635796 Fax: +44 (0)1455 251110
Email: sales@asp-electro-tech.com Web: asp-electro-tech.com



This publication is not intended to form the basis of a contract. All the above specifications, dimensions, weights, tolerances etc are typical and may be varied or changed by the manufacturer without prior notice. A.S.P. Electro-Technology accept no liability for consequence of use.